

## SERIES - MI-H-HFEU

### FLANGE BASE - HEIGHT WITH EXTENDED U SHAPED HOLD DOWN ARM

Supplied with Spindle assemblies & Flange washers. Silicon rubber grip having large grip surface with oil & heat resistance.

This series has two major points :

Its with max clearance below the clamping arm were the job with maximum thickness can be held.  
This series has a long holding arm which helps to hold the job to the maximum extended length.

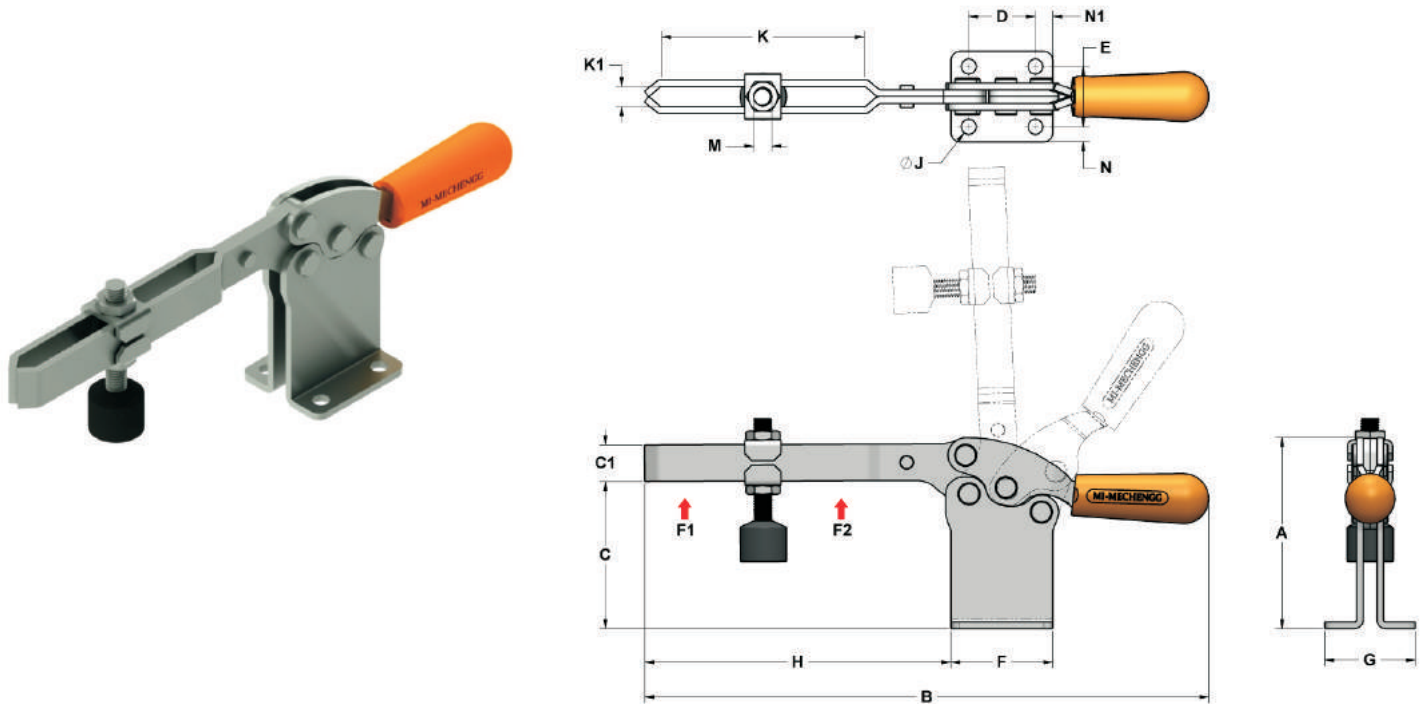

- Material : Steel
- Surface Finish : Electro Zinc - Plated
- Hand Grip : Silicon Rubber
- Clamping Bolt : 8.8 grade Moulded with NBR

PART NO	ARM OPENS	HANDLE MOVES	HOLDING CAPACITY		APPROX ⚖️ (Kg's)	SPINDLE SUPPLIED (METRIC) PART NO
			F1 (N)	F2 (N)		
MI-H-75-HFEU	79°	53°	230	500	0.200	NTS-H50
MI-H-150-HFEU	79°	56°	600	1000	0.288	NTS-H150
MI-H-250-HFEU	88°	58°	1000	2000	0.405	NTS-H250

Note : For Spindle dimensions refer accessories page

PART NO	A	B	C	C1	D	E	F	G	H	J	K	K1	M	N	N1
MI-H-75-HFEU	71.5	162.5	54	14	19	19.4	30	30	71.5	4.5	47	5.5	M5	5.3	5.5
MI-H-150-HFEU	71.5	177	57.5	14	24	23.4	35	34	84	4.5	55	6	M6	5.3	5.5
MI-H-250-HFEU	84.5	249.5	65	16	29.5	26.6	45	40	135.5	6.6	90	9	M8	6.7	7.7