

SERIES - MI-V-SS

STRAIGHT BASE SOLID HOLD DOWN ARM

Supplied with Spindle assemblies & Spindle retainer. Clamp runs with specially designed pre-lubricated bushes for long life cycle, Silicon rubber grip having large grip surface with oil & heat resistance.

Spindle retainer supplied loose for welding in the desired position.

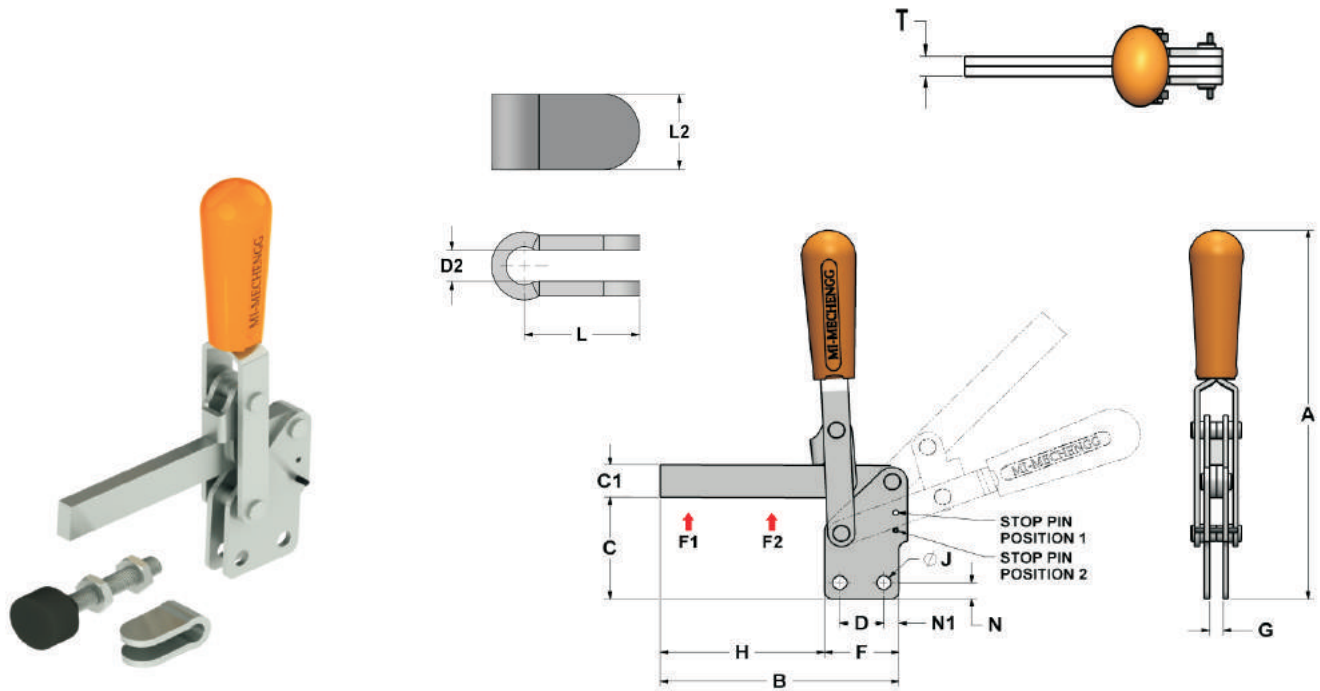

- **Material** : Steel
- **Surface Finish** : Electro Zinc - Plated
- **Hand Grip** : Silicon Rubber
- **Clamping Bolt** : 8.8 Grade Moulded with NBR

PART NO	ARM OPENS AT PIN 1	HANDLE MOVES AT PIN 1	ARM OPENS AT PIN 2	HANDLE MOVES AT PIN 2	HOLDING CAPACITY F1 (N) ↑	HOLDING CAPACITY F2 (N) ↑	APPROX (Kg's)	SPINDLE (METRIC) PART NO	SPINDLE RETAINER PART NO
MI-V-150-SS	55°	50°	120°	72°	0750	2000	0.415	NTS-V150	SRV-150
MI-V-250-SS	85°	55°	135°	72°	1250	3000	0.680	NTS-V250	SRV-250
MI-V-350-SS	50°	40°	108°	60°	1780	4000	0.975	NTS-V350	SRV-350
MI-V-450-SS	60°	52°	125°	77°	2250	5000	1.275	NTS-V450	SRV-450

Note : For Spindle & Spindle Retainer dimensions refer accessories page

PART NO	A	B	C	C1	D	F	G	H	J	N	N1	T
MI-V-150-SS	175.5	108	54	16	19	36	6	72	7	6.5	8.5	6
MI-V-250-SS	228	141	63	20	26	44	8	97	8.5	-	9	8
MI-V-350-SS	243	153	73	21	31	49	8	104	8	9	9	8
MI-V-450-SS	260	178	72	25	32	56	10	122	9	10	12	10