

MI - HORIZONTAL CLAMPING ARM / FLANGE BASE - FIXED BUSH

These Flange base horizontal clamping arm with bush to weld in desired position to suite the locking object as per the application. These models feature with the Flange base for situation where a horizontal surface is used to mount the clamp, which can be directly bolt mounted or welded to a fixture. These series clamp have less height under the clamping bar compare to straight base series . This series allows wide opening angle which enables easy loading and unloading of the workpiece. All MI clamps comes with an unique silicon rubber grip which is only manufactured by MI which withstands high temperatures at work place.

These clamps are finished black oxide,

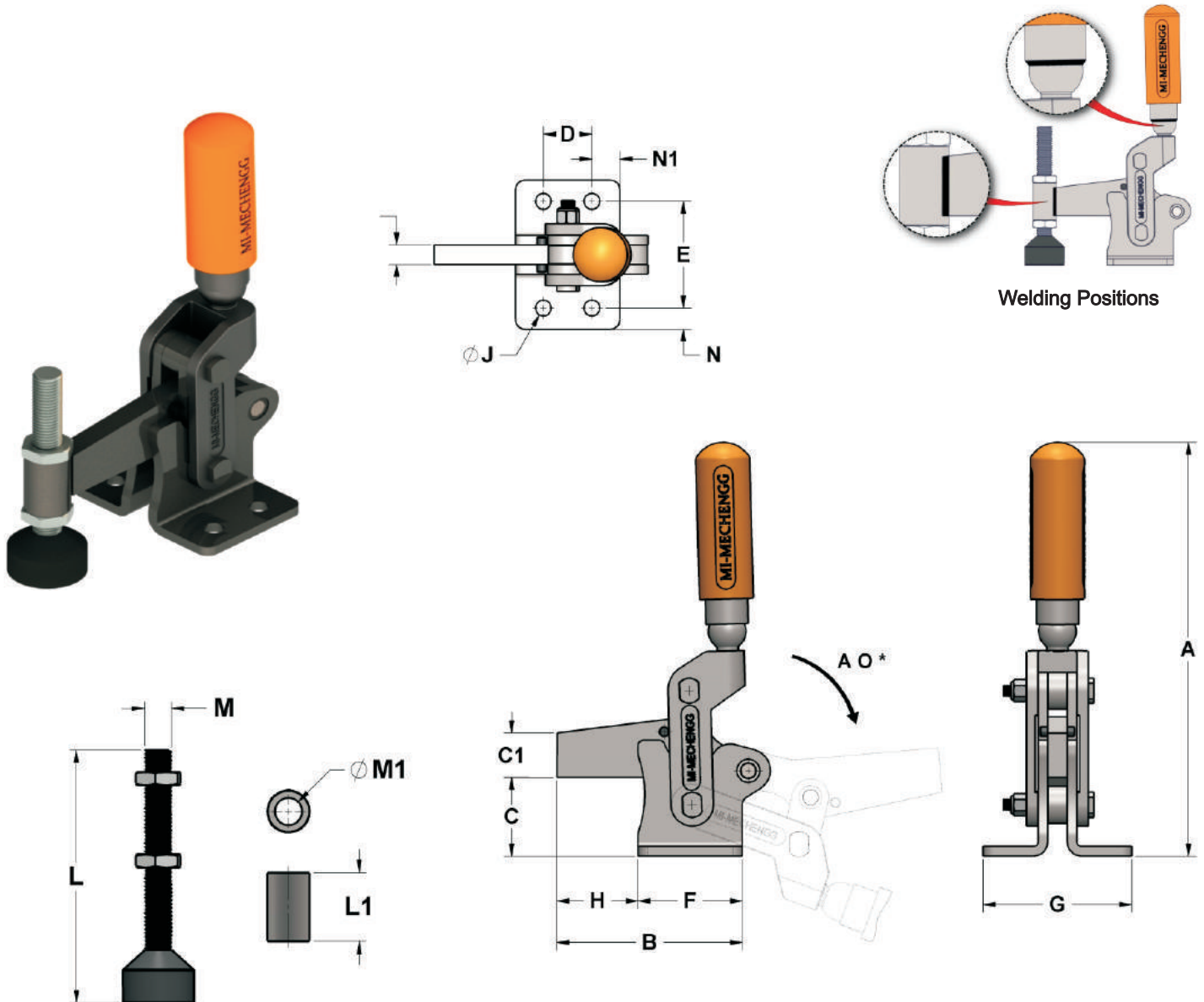

PART NO	AO	A	B	C	C1	D	E	F	G	H	J	L	L1	M	M1	N	N1	T
MI-AMV-700-WB/FB	175	214	96	40.7	23	25.1	55.1	54	77	42	8.2	114	31	12	12.2	10.95	14.5	10
MI-AMV-1200-WB/FB	173	256.3	117.1	51	27	30.1	60.1	65	83	52	8.2	114	35	12	12.2	11.45	17.45	12
MI-AMV-2500-WB/FB	190	324.1	132	77.3	33	40.1	75.1	70	105	62	10.2	-	-	-	-	14.95	14.95	16